



PHELON & MOORE
MOTORS

Panthette X 300

Owner's manual

PHELON & MOORE
MOTORS

PHELON & MOORE

MOTORS



PHELON & MOORE

MOTORS

Dear Rider,

Welcome to the Phelon & Moore family! You've made an exceptional choice, and we're thrilled to have you with us. Owning a Phelon & Moore isn't just about having a motorcycle of outstanding quality – it's about being part of a legacy where tradition, innovation, and passion meet the open road.

For your safety, and to keep your motorcycle performing at its best, we encourage you to dive into this user manual. Here, you'll find all the tips and guidance you need to fully enjoy your Phelon & Moore experience. When it's time for maintenance or repairs, trust only our authorized service partners who share the same dedication to excellence.

This manual also outlines the pre-delivery checks performed on your bike, the warranty terms, maintenance schedules, and service intervals. And remember, for the best performance and reliability, always choose original Phelon & Moore parts.

At Phelon & Moore, our commitment is to ensure you have the *perfected motorcycle*. Here's to many unforgettable journeys ahead!

Ride safe,
The Phelon & Moore Team

PHELON & MOORE

MOTORS

Pre-Delivery Inspection (PDI) Document

Date:

Inspection Location:

1. Vehicle Identification

Model Name:

VIN (Vehicle Identification Number):

Engine Number:

2. Exterior & Body Inspection

- No visible scratches, dents, or damage
- Proper alignment of panels and components

Technician Name:

Customer Name:

Mirrors and windscreen secured

Correct paint finish and decals

3. Mechanical Inspection

Engine starts and idles smoothly

No abnormal noises or vibrations

Fluids (oil, coolant, brake fluid) at recommended levels

No leaks detected

4. Electrical System

Headlights, taillights, and functional indicators

PHELON & MOORE

MOTORS

- Horn works correctly
- Battery voltage and connections verified

5. Functional Testing

- Brakes operate effectively
- Clutch and gear shifting smooth
- Suspension responds properly
- Wheels and tires correctly inflated and aligned

6. Compliance & Safety Check

- Owner's manual and warranty documents included

7. Final Approval & Sign-Off

Technician Signature:

Supervisor Signature:

Customer Confirmation:

PHELON & MOORE

MOTORS

Table of Contents

General Warranty Conditions

Rider Rights

Warranty Exclusions

General Instructions

Overview

Abbreviations & Symbols

Technical Data

Vehicle Operating Data

Motorcycle Identification

Running-in Period

Motorcycle Structure

Rider view

Clutch Lever

Left Commands

Windshield Adjuster

7" TFT Display

PHELON & MOORE

MOTORS

1. Instrument Panel
2. Light sensor
3. Driving Mileage
4. Gear
5. Speed
6. Rotational speed
7. Mileage Information
8. Fault Information
9. Maintenance Mileage
10. Software Version
11. Mobile Connection

Front Brake Lever

Right Commands

Ignition Switch

Fuel Tank

Coolant

Front Suspension Adjustment

PHELON & MOORE

MOTORS

Rear Suspension Adjustment

Engine Oil

Checking the Oil Level

Topping Up the Oil

Oil Capacity

Battery

Brake fluids

Braking system, wheels, and tires

[Maintenance schedules](#)

[General Warranty Conditions](#)

[Rider Rights](#)

Phelon & Moore guarantees all new motorcycles for a period of thirty-six (36) months (with no mileage limits) against any defects identified and acknowledged by the company. The warranty period commences from the date of the motorcycle's delivery.

PHELON & MOORE

MOTORS

In the event of a defective product, the rider is entitled to have it repaired or replaced at no cost. Any defective parts replaced under warranty remain the property of Phelon & Moore.

These “General Warranty Conditions” are in addition to the mandatory rights afforded to riders under legislation implementing Directive 1999/44/EC.

The warranty obligation extends to motorcycle components not manufactured directly by Phelon & Moore, excluding consumable components. Normal wear and tear of the motorcycle or its components (or wear resulting from unusual or extraordinary use by the rider) are not covered under the warranty.

Warranty Exclusions

The warranty does not extend:

1. To motorcycles used in competitions of any kind.
2. In cases where the defect is reported after an undue delay.
3. To motorcycles where fuels, lubricants, or liquids not specified by Phelon & Moore have been used.
4. To components subject to normal wear and tear, such as belts, control hoses, spark plugs, batteries, tyres, brake pads, clutch discs, and secondary transmission components (e.g., sprockets, chains, etc.).

PHELON & MOORE

MOTORS

5. To wear and tear parts replaced during routine maintenance, including oil, filters, and spark plugs.
6. To parts damaged as a result of oxidation or exposure to atmospheric conditions.
7. To defects of which the rider was aware at the time of signing the sales contract.
8. To motorcycles repaired in workshops unauthorized by Phelon & Moore, whether this is the cause or a contributing factor to the issue; such instances may also be considered product alteration in certain conditions.
9. To motorcycles fitted with non-original or non-approved spare parts, whether this is the cause or a contributing factor to the issue; such instances may also be considered product alteration in certain conditions.
10. In cases where the rider was aware of the defect or could not reasonably have been unaware of it through ordinary care.
11. Where the defect or fault arises due to instructions or materials provided by the rider.

▶ **ATTENTION** The warranty does not cover any damage arising from the use of accessories not specified for the product, not approved, incompatible with the structural characteristics of the motorcycle, or not installed in accordance with the technical specifications of the manufacturer or Phelon & Moore. This includes, but is not limited to, damage caused by accessories such as windscreens, luggage racks, top cases, side bags, fairings, or additional lighting units.

PHELON & MOORE

MOTORS

Additionally, the warranty excludes damage resulting from or related to road accidents, improper use, overloading, or failure to perform ordinary or extraordinary maintenance as outlined in the owner's manual or appropriate for the type of product and its intended use.

General Instructions

Overview

This *Rider's Manual* serves as your introduction to the refined engineering of your motorcycle. Within these pages, you will find comprehensive documentation of all maintenance and servicing requirements, ensuring your machine remains in impeccable condition. Keeping a meticulous record of these procedures is essential, as it may enhance any goodwill claims extended to you.

Should the time come to pass your motorcycle on to its next custodian, be sure to present them with this manual. It is not merely a guide—it is an integral part of the motorcycle's legacy, embodying the craftsmanship and prestige that define Phelon & Moore.

Abbreviations & Symbols



CAUTION – A minor hazard that may cause slight or moderate injury if ignored. Exercise care when proceeding.

PHELON & MOORE

MOTORS



WARNING – A significant hazard that may result in severe or fatal injury if disregarded. Take immediate precautions.



DANGER – A critical hazard that will lead to severe or fatal injury if neglected. Extreme caution is required.



ATTENTION – Advisory notes and precautionary measures. Failure to comply may result in damage to the motorcycle or accessories, potentially invalidating the warranty.



NOTICE – Specific guidance on operating, controlling, adjusting, or maintaining various features of the motorcycle.

ABS – Anti-lock Brake System

TCS – Traction Control System

TPMS – Tyre Pressure Monitoring System

PHELON & MOORE

MOTORS

Technical Data

All measurements, weights and performance figures quoted in this manual are in accordance with recognized standards and comply with the tolerance limits set by our Quality Control Engineers.

Engine

- Type: Single cylinder, 4-stroke, liquid-cooled, 4 valves
- Displacement: 276 cm³
- Idle Speed: 1600 ± 150 rpm
- Maximum power: 23.5 hp @ 8200 rpm
- Bore x stroke: 72.5mm x 66.8mm
- Gearbox: CVT
- Cooling System: Water-cooled
- Lubrication: 10W/40 SF

For precise and definitive data, please refer to the vehicle's registration documents, identification plates, or consult your authorized Phelon and Moore retailer or an approved

PHELON & MOORE

MOTORS

service specialist. Where differences arise, the information contained in the official vehicle documentation shall always take precedence over that found in this manual.

Vehicle Operating Data

Various control units within the motorcycle process operating data to ensure smooth performance. This may include, for example:

- Status updates from the motorcycle and its components, such as wheel rotation, speed, or deceleration
- Environmental readings, such as ambient temperature

This data is typically processed only while the vehicle is in use and is not stored permanently.

Certain electronic systems, such as control units, may include memory components capable of temporarily or permanently storing technical data. This information may relate to the vehicle's condition, system loads, faults, or irregularities. Examples include:

- System operating conditions such as fluid levels or tyres pressure
- Malfunctions or faults in key components like lighting or braking systems
- Vehicle responses during specific riding scenarios, such as traction control interventions
- Records of incidents that may have caused damage to the motorcycle.

PHELON & MOORE

MOTORS

Such data is essential for the correct functioning of control units and is also used to diagnose faults, assist in repairs, and improve future vehicle performance. Most of this data is temporary and processed only within the motorcycle itself. In some cases, however, certain events may result in data being saved in error memory or incident logs.

When service or repair work is carried out — including warranty checks or quality control procedures — this technical information may be retrieved, along with the vehicle's identification number.

This is done via the legally required On-Board Diagnostics (OBD) interface and may be accessed by an authorized Phelon and Moore retailer or any suitably qualified specialist workshop.

The data is collected, processed and used within our authorized service network. It serves to verify the motorcycle's technical condition, support troubleshooting, meet warranty commitments, and assist in maintaining the highest standards of quality.

PHELON & MOORE

MOTORS

Motorcycle Identification

Your motorcycle is marked with two unique identifiers used for registration, servicing, and legal documentation: the VIN (Vehicle Identification Number) and the Engine Number.

VIN – Vehicle Identification Number

- The VIN is located under the passenger seat, stamped onto the motorcycle frame.
- It is a 17-character alphanumeric code that uniquely identifies your vehicle.
- This number is required for registration, insurance, and servicing records.

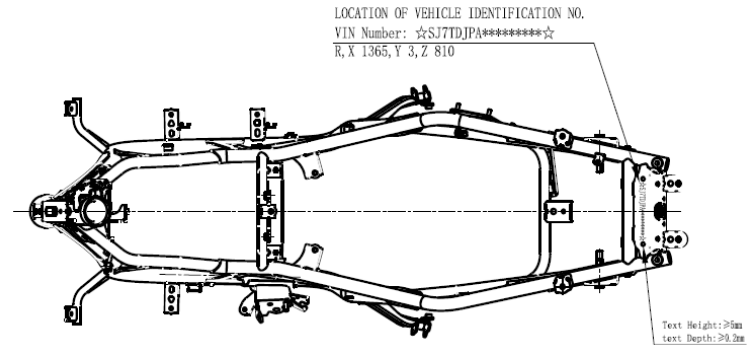

Tip: Lift the passenger seat to access the frame section where the VIN is stamped. Keep this area clean and legible at all times.

PHELON & MOORE

MOTORS

Engine Number

- The Engine Number is located on the front section of the engine, just behind the front wheel.
- This number helps identify the engine unit for technical support, warranty claims, and parts compatibility.

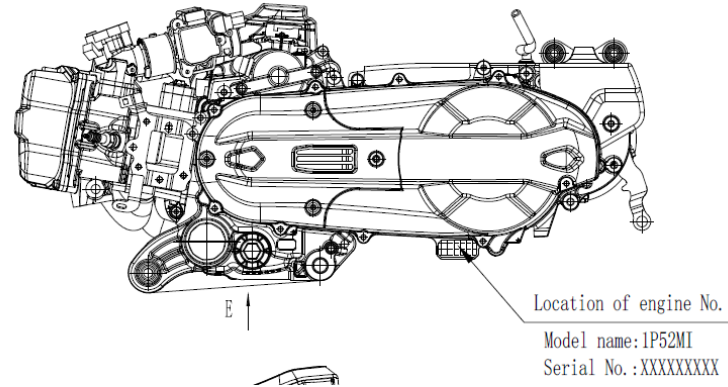

Caution: Ensure the motorcycle is on a stable stand and cooled down before inspecting the engine number, as engine parts can be hot and difficult to access when recently used.

PHELON & MOORE

MOTORS

Running-in Period

Your new Phelon & Moore motorcycle has been built to the highest standards of performance and craftsmanship. To ensure it delivers peak reliability and longevity, it's essential to allow all components to bed in properly during the initial running-in period.

First 1,000 km – Take it Steady

During the first 1,000 kilometers, we recommend:

- Avoid full throttle or high engine revs. Keep the engine speed below 6,000 rpm.
- Vary your speed and engine load — avoid riding at a constant throttle or engine speed for extended periods.
- Use gentle acceleration and deceleration to help all mechanical parts seat correctly.
- Do not allow the engine to idle excessively or overheat while stationary.

PHELON & MOORE

MOTORS

First Service at 1,000 km

At around 1,000 km, your motorcycle should undergo its initial service at an authorized Phelon & Moore service center. This includes:

- Oil and filter change
- Inspection and adjustment of valve clearance
- Checking of all fluids, fasteners, and key systems
- Ensuring proper wear-in of brake pads and drivetrain

After 1,000 km – You're Ready

Once the running-in service is complete, your motorcycle is ready to be enjoyed to its fullest. You may begin to explore its full performance range, though we still recommend increasing engine loads progressively.

Respecting the running-in process is essential to maintaining engine health and preserving your warranty. Consult your service schedule for detailed intervals and inspection items.

PHELON & MOORE

MOTORS

Left Commands

The left-hand control cluster places essential functions at your fingertips, allowing you to interact seamlessly with the motorcycle's systems while keeping your focus on the road.

Menu Navigation Buttons

The Up, Down, Back, and Set buttons are used to navigate through the display screens and menu options shown on the 7" TFT display. These controls give you access to:

- Riding information
- Trip data
- Vehicle settings
- Connectivity and media functions

Lighting and Indicators

- The Turn Signal Switch allows you to indicate left or right turns with a smooth, tactile action.
- The High Beam Button activates or flashes the high beam for increased visibility when required.



PHELON & MOORE

MOTORS

The left command cluster is designed for intuitive use, even while wearing gloves, ensuring that form and function work in harmony with every ride.



CAUTION Only interact with the display and handlebar controls when it is safe to do so. Never allow the use of on-board functions to distract you from the road ahead. Your full attention is essential for your safety and the safety of others.

Windshield Adjuster

Your motorcycle is equipped with an *on-the-go windshield adjuster*, allowing you to fine-tune wind protection to suit changing conditions while riding.

The windscreen can be manually adjusted to one of several positions, offering optimal airflow management for both comfort and aerodynamics.

Adjusting the windshield allows you to:

- Reduce wind buffeting at higher speeds
- Tailor airflow for rider height and seating position

PHELON & MOORE

MOTORS

Adjustment Procedure:

While seated, simply grasp the adjuster and move the screen smoothly up or down to your preferred height. Always ensure the screen is securely set before continuing your journey.



CAUTION: For safety, make only small adjustments while the motorcycle is in motion, and always maintain full control of the vehicle.

7" TFT Display

A high-resolution, full-color screen presenting essential riding information, navigation, and settings in a stylish and intuitive layout.

PHELON & MOORE

MOTORS

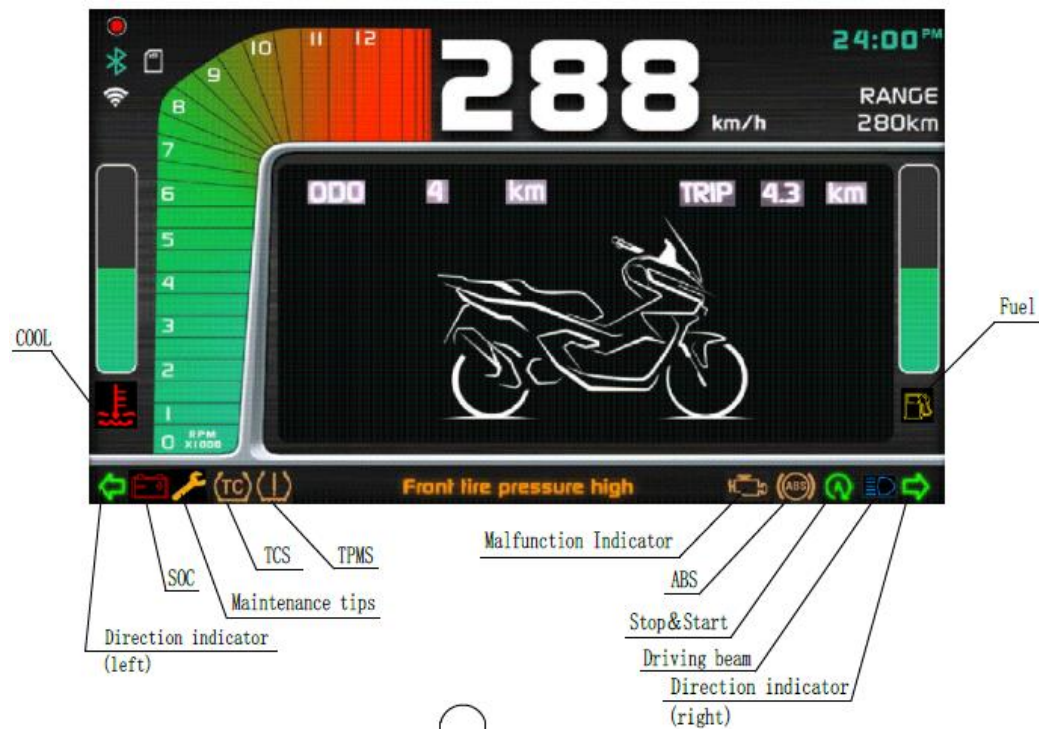





PHELON & MOORE

MOTORS

1. Instrument Panel









There are 9 indicator lights on the instrument panel, plus a light sensor, and some indicator lights are displayed on the TFT screen.

When the vehicle is powered on, some indicator lights will light up. After the system completes self-check or the vehicle starts, if the vehicle system is normal, the indicator lights will go off. Some indicator lights being on indicate the status information of vehicle system functions, not system faults.

Symbol	Description
	The indicator light flashes when the left turn signal or hazard warning light is turned on.
	The indicator light flashes when the right turn signal or hazard warning light is turned on.
	The indicator light is on when the high beam is turned on.
	The indicator light is on when the low beam is turned on.
	The indicator light is on when there is an engine malfunction.









PHELON & MOORE

MOTORS

Symbol	Description
	The indicator light is on when the engine coolant temperature is too high.
	The indicator light is on when there is a fault in the ABS system.
	The indicator light is on when the engine oil pressure is abnormal.
	The indicator light is on when the dashcam is recording.
	The indicator light is on when the dashcam is not recording.
	The indicator light is on when the handle heating function is activated.
	The indicator light is on when the seat heating function is activated.
	The indicator light is on when the position lights are turned on.

PHELON & MOORE

MOTORS

Symbol	Description
	The indicator light is on when the instrument Wi-Fi is connected to another device.
	The indicator light is on when the instrument Bluetooth/BLE is connected to another device.
	The indicator light is on when the battery voltage is $<12V$ or $\geq 15V$.
	The indicator light is on when the battery voltage is between 12V and 15V.
	The indicator light is on when the remaining maintenance mileage is $\leq 50km$.
	The TCS disable indicator light is on when the TCS function is turned off.
	The indicator light is on when the TCS function is turned on; it flashes when TCS is intervening.
	The indicator light is on when there is a fault in the tire pressure system or abnormal tire status.

PHELON & MOORE

MOTORS

2. Light sensor

There is 1 light sensor hole on the instrument panel, which is used to collect ambient brightness and automatically adjust the screen brightness to a suitable level based on ambient brightness.

3. Driving Mileage

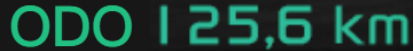

ODO 125,6 km

The driving mileage on the main interface includes ODO (total cumulative driving mileage), TRIPA (cumulative driving mileage for a certain period), and TRIPB (single trip mileage). The three mileages are displayed in the same position: short press the "Up" button to switch the display between ODO/TRIPA/TRIPB in sequence.

In Menu - Vehicle Information - Mileage Information - TRIP A, short press the "SET" button to reset the TRIP A mileage; the TRIP B mileage is automatically reset every time the power is turned off.

This setup is intuitive and allows for quick, confident shifting whether you're navigating city traffic or exploring open roads.

4. Speed



Displays the current driving speed of the vehicle (km/h - kilometers per hour, or mph - miles per hour).

5. Rotational speed

Displays the current rotational speed of the engine (rpm - revolutions per minute), with 10-12 being the high rotational speed range.

PHELON & MOORE

MOTORS

6. Mileage Information

Maximum speed (km/h or mph). Shortly press the "Up/Down" button to switch between ODO/TRIPA/TRIPB.

On the TRIPA interface, short press the "SET" button to reset the TRIPA mileage (a reset confirmation prompt interface will appear; short press the "Up/Down" button to switch between cancel/confirm options); the TRIPB mileage is automatically reset every time the instrument is powered off.

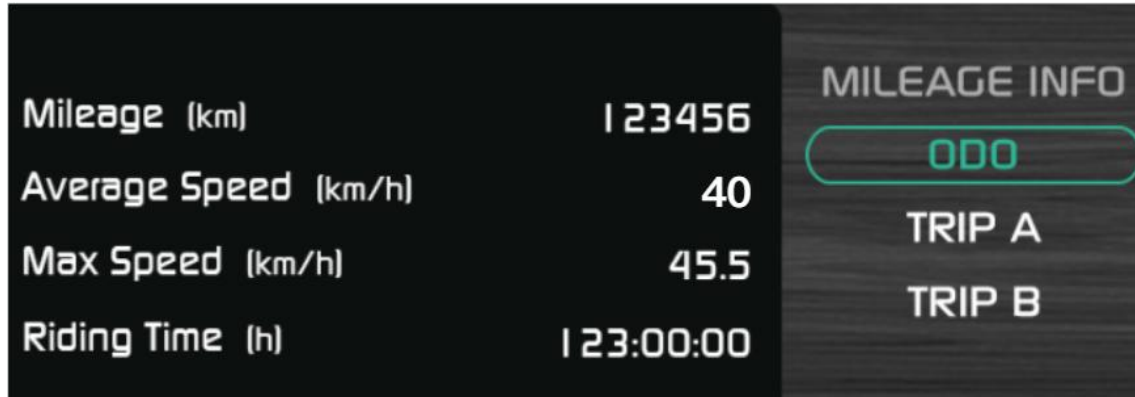

7. Fault Information

The Fault Information List allows you to view real-time diagnostics of the motorcycle's systems via the TFT display.

- When a system error or malfunction is detected, the fault will be listed automatically.
- Riders are advised to visit a Phelon & Moore Authorized Service Centre as soon as possible should any fault appear on the list.
- If no issues are present, the screen will display: "No fault content".

This feature provides a quick and intuitive way to monitor the health of your motorcycle and maintain peak performance and safety.

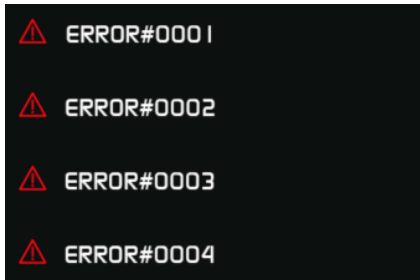

PHELON & MOORE

MOTORS

8. Maintenance Mileage

The interface displays the current remaining maintenance mileage of the vehicle. When the remaining maintenance mileage is ≤ 50 km, the maintenance indicator light is displayed on the main interface.

Shortly press the "SET" button to reset the remaining maintenance mileage. A pop-up window will confirm "Reset remaining maintenance mileage?" Use the "Up/Down" buttons to switch options; after confirmation, the remaining maintenance mileage will be reset. After the first maintenance mileage reset, the remaining mileage will become a periodic maintenance mileage of 5000km (the default maintenance cycle after each reset is 5000km).

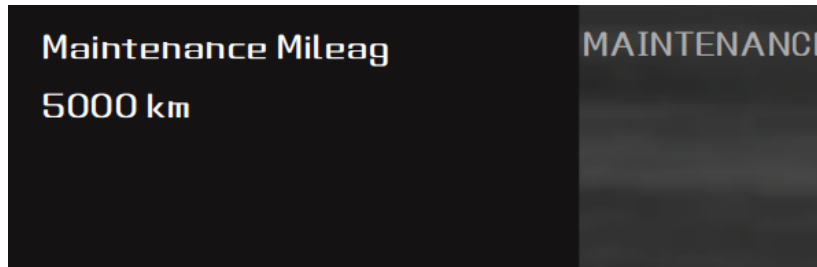



9. Mobile Connection

To enable mobile phone connectivity and unlock smart features such as navigation, media access, dashcam viewing, and OTA updates, the motorcycle uses the MotoFun mobile app, available for download from your preferred app store.

Steps to Connect:

1. **Download and Install**
Search for and install the MotoFun app from your mobile device's app store.
2. **Initiate Connection on the Motorcycle**
 - Long press for 3 seconds the SET button in the home screen of your motorcycle to go to the **PHONE SCREENING MENU**.
 - A QR code will be displayed on the screen with the connecting data of your motorcycle:

PHELON & MOORE

MOTORS



3. Connect Using the App

- Open MotoFun on your mobile device.
- Tap “Connect New Vehicle” to enter the scanning mode.
- Scan the QR code shown on the instrument cluster.
- Once connected, navigation mode will begin automatically.

4. Connect the Apps

Within the Motofun app, you'll find a section called “My Applications”. This lets you manage which mobile apps are displayed on your motorcycle's screen when mirroring is active.

PHELON & MOORE

MOTORS

- Tap “My Applications” from the Motofun main screen.
- Select the apps you wish to enable for projection (e.g., maps, music, weather).
- Once selected, these will be accessible via the TFT during projection mode.

This allows you to personalize your riding experience and access only the information that matters most — all while keeping your focus on the road.

5. Dashcam Access

- After connection, go to “Main Interface” → “My Applications” → “Dashcam” in the app.
- Here, you can view and manage dashcam videos and photos stored in the album.

Connection Methods:

- The system supports connections via Bluetooth, Wi-Fi, or both for enhanced data speed and stability.

PHELON & MOORE

MOTORS

Connected OTA (Over-the-Air Updates)

Once your mobile device is connected:

- The MotoFun app will check the instrument's current software version.
- If a new version is available, you will receive a download prompt in the app.
- Confirm to start downloading the update.

Upgrade Installation:

- After downloading, the update will be transferred to the TFT instrument.
- If the vehicle is stationary (N gear and speed 0), the instrument will automatically initiate the upgrade.
- Note: The upgrade process will not start during riding for safety reasons.

Front Brake Lever

Positioned on the right handlebar, it activates the front braking system with responsive precision. This lever engages and disengages the front wheel ABS brake. For enhanced rider

PHELON & MOORE

MOTORS

comfort, the clutch lever can be adjusted to suit individual preferences using the integrated adjustment dial.

To select one of the five available positions, gently push the lever forward and rotate the ring nut regulator. Align the indicator arrow (A) with the desired setting.

- Position 1 places the clutch lever furthest from the right handlebar grip.
- Position 5 brings the lever closest to the grip.

This adjustment allows you to tailor the brake reach for optimum control and comfort during every ride.

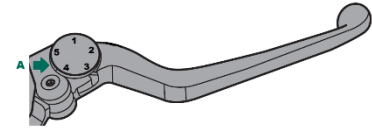

Right Commands

A set of ergonomic controls for throttle modes, engine start/stop, and other key functions.

PHELON & MOORE

MOTORS

Electric Start Switch

The electric start switch allows for safe and reliable engine ignition under the following conditions:

When the gearbox is neutral and the side stand is retracted, press the start button down to start the engine.



Note: While the fog lights are fully functional when switched on, there is no dedicated indicator on the TFT display to confirm their status. Always ensure you are familiar with the button's position and use visual confirmation where possible.



Caution: Fog lights should only be used in poor visibility conditions. Prolonged use in clear weather may cause discomfort to other road users and may not comply with local regulations.



PHELON & MOORE

MOTORS

Ignition Switch

The ignition switch is used to power on the motorcycle and start the engine. To operate the switch, the rider must have the correct motorcycle key present.

Turning the switch enables access to the vehicle's electrical systems, including the TFT display, lighting, and starter functions.

To make it easier to engage the steering lock, move the handlebar slightly while turning the key.

Refueling

Secures access to the fuel tank; designed for easy operation while maintaining a refined appearance. Push the cap to access the fuel tank.

Refueling

Refuel the motorcycle only outdoors, with the engine switched off.

PHELON & MOORE

MOTORS



DANGER:

- Never smoke or expose open flames while refueling.
- Take care to avoid spilling fuel on the engine or exhaust, as this may pose a fire hazard.
- Do not overfill the tank — fuel should never reach or touch the filler recess rim. Leave sufficient space for expansion.
- Avoid inhaling fuel vapors and prevent contact with eyes, skin, or clothing.

Always close the fuel cap securely after filling and wipe away any spills immediately using a clean cloth.

12V Connector

A conventional power outlet for connecting compatible devices and accessories.

USB Connector

Provides a modern charging point for mobile devices and navigation aids.

Coolant

To maintain optimal engine performance and safety, always check the coolant level before each ride. The coolant must also be replaced at the intervals specified in the scheduled maintenance chart. You may find the coolant reservoir in the inner part of the front right panel.

PHELON & MOORE

MOTORS

Checking the Coolant Level

1. Place the motorcycle on a flat, stable surface and keep it upright.

Note:

- Always check the coolant when the engine is cold, as levels rise and fall with temperature.
- Ensure the motorcycle is completely upright; even a slight lean may affect the reading.

2. View the coolant level through the reservoir. The level should be between the *MIN* and *MAX* markings.
3. If the coolant is at or below the *MIN* mark, remove the coolant reservoir cap.



Warning: Only remove the coolant reservoir cap. Never attempt to open the radiator cap when the engine is hot, as this may cause serious injury from hot pressurized fluid.



4. Top up the coolant reservoir with the recommended coolant (or distilled water, if necessary) until it reaches the *MAX* level mark. Refit the reservoir cap securely.

PHELON & MOORE

MOTORS

Troubleshooting

Symptom	Possible Cause	Recommended Action
Engine won't start	<ul style="list-style-type: none">• Empty fuel tank• Battery discharged• Kill switch OFF• Sidestand down or bike in gear• Faulty starter button	<ul style="list-style-type: none">• Refuel• Charge or replace battery• Set kill switch to ON• Retract sidestand and pull clutch• Contact dealer if issue persists
Engine cranks but doesn't start	<ul style="list-style-type: none">• Fuel injection issue• Air filter clogged• Spark plug issue	<ul style="list-style-type: none">• Check EFI system• Clean or replace air filter• Inspect spark plug and wiring
Engine stalls or idles roughly	<ul style="list-style-type: none">• Low fuel pressure• Dirty air filter• Incorrect idle setting	<ul style="list-style-type: none">• Check fuel supply• Clean/replace air filter• Adjust idle if possible
Poor acceleration	<ul style="list-style-type: none">• TCS overly active• Low tire pressure• Dirty injector	<ul style="list-style-type: none">• Check TCS settings• Inflate tires to correct pressure• Have injectors checked

PHELON & MOORE

MOTORS

Symptom	Possible Cause	Recommended Action
Excessive engine vibration	<ul style="list-style-type: none"> • Engine mounting bolts loose • Chain too tight/loose 	<ul style="list-style-type: none"> • Inspect and tighten bolts • Adjust chain tension
Engine overheating	<ul style="list-style-type: none"> • Low coolant level • Radiator fan not working • Coolant leak 	<ul style="list-style-type: none"> • Check coolant reservoir • Inspect fan operation • Look for leaks
Brake feels spongy	<ul style="list-style-type: none"> • Air in brake lines • Low brake fluid 	<ul style="list-style-type: none"> • Bleed brake system • Refill with DOT4 fluid
ABS/TCS warning stays on	<ul style="list-style-type: none"> • Sensor misalignment • Fault detected in system 	<ul style="list-style-type: none"> • Inspect sensors • Consult service center if light remains on
TFT not connecting to phone	<ul style="list-style-type: none"> • Bluetooth/Wi-Fi off • App not paired • QR code not scanned properly 	<ul style="list-style-type: none"> • Enable Bluetooth/Wi-Fi • Use MotoFun app • Re-scan QR from TFT menu

PHELON & MOORE

MOTORS

Symptom	Possible Cause	Recommended Action
Low tire pressure warning	<ul style="list-style-type: none"> • Tire puncture • Tire Pressure Monitoring System (TPMS) reading low 	<ul style="list-style-type: none"> • Check tires for punctures • Inflate to correct pressure
Oil warning light stays on	<ul style="list-style-type: none"> • Low oil level • Oil sensor malfunction 	<ul style="list-style-type: none"> • Check sight glass • Add oil if needed • Visit service if persists
Excessive smoke from exhaust	<ul style="list-style-type: none"> • Oil overfilled • Worn piston rings 	<ul style="list-style-type: none"> • Drain excess oil • Contact authorized dealer
Battery drains quickly	<ul style="list-style-type: none"> • Accessories left on • Faulty battery 	<ul style="list-style-type: none"> • Turn off unused electronics • Test or replace battery
Gear shifting difficulty	<ul style="list-style-type: none"> • Clutch not fully disengaging • Low clutch fluid • Chain tension off 	<ul style="list-style-type: none"> • Adjust clutch cable or fluid • Check chain tension

PHELON & MOORE

MOTORS

Symptom	Possible Cause	Recommended Action
Unusual noise from engine	<ul style="list-style-type: none">• Loose component• Valve clearance out of spec	<ul style="list-style-type: none">• Inspect external bolts• Schedule valve clearance check

PHELON & MOORE

MOTORS

Front Suspension

The Panhette X is equipped with a 41 mm upside-down front fork, designed to provide enhanced rigidity and precise front-end feedback during riding.

The fork offers a 120 mm suspension travel, allowing it to effectively absorb road irregularities, improve braking stability, and enhance overall control and riding comfort in both urban conditions and uneven surfaces.



Warning: Do not modify or replace suspension components with non-original parts. Doing so may compromise safety and void the warranty.

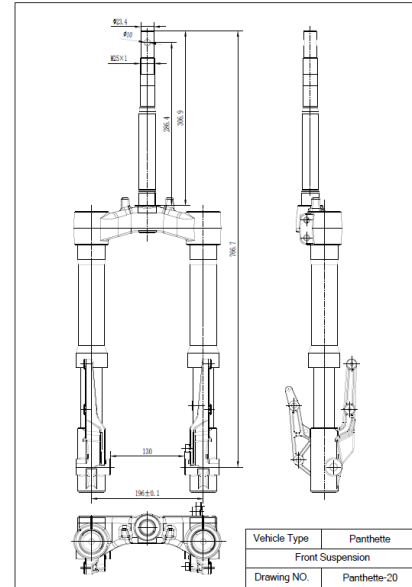

PHELON & MOORE

MOTORS

- Visually inspect every 3,000 km for oil leaks or structural deformation.
- Do not disassemble the shock absorber without specialized tools.
- If performance deteriorates, contact an authorized distributor for inspection or replacement.



Warning: Do not modify or replace suspension components with non-original parts. Doing so may compromise safety and void the warranty.

Air Filter Maintenance

Maintaining a clean air filter is essential for optimal engine performance and fuel efficiency. A dirty or clogged air filter can reduce airflow, affecting power output and increasing fuel consumption. The air filter is located beneath the rider's seat and is easily accessible for inspection, cleaning, or replacement.

Accessing and Servicing the Air Filter

Follow these steps to remove and clean or replace the air filter:

1. Remove the filter cover.
2. Remove the rider seat to expose the air filter housing.

PHELOM & MOORE

MOTORS

3. Locate the black air filter box beneath the rider seat. It is secured with four bolts.
4. Unscrew the four bolts to open the air filter housing.
5. Remove the air filter:
 - If you are cleaning the filter: use compressed air or gently tap out the dust. Avoid using water or solvents unless specified by the filter manufacturer.
 - If you are replacing the filter: insert a new, compatible air filter into the housing.
6. Reassemble by tightening the bolts securely, then refit the rider and passenger seats in reverse order.

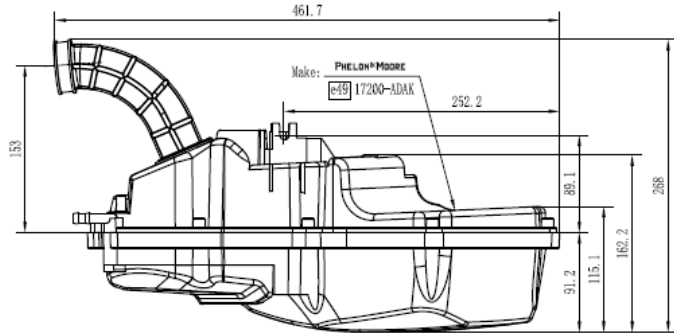

PHELON & MOORE

MOTORS



Important: Always make sure the air filter is correctly seated and that no dust or debris enters the intake when the box is open.

Engine Oil

Use only 10W/40 SF grade engine oil, as specified for optimal performance and protection.

Topping Up the Oil

If the oil is below the required level:

- Remove the oil filler plug (2).
- Carefully top up with the recommended engine oil.
- Once the correct level is reached, refit the plug securely.

Battery

The motorcycle is equipped with a 12V – 11.5Ah maintenance-free battery, located under the rider's seat. This battery powers the vehicle's electronic systems, including the starter motor, lights, TFT display, and ECU.

Accessing the Battery:

1. Ensure the motorcycle is off and on a stable surface.

PHELON & MOORE

MOTORS

2. Remove the rider's seat using the seat release mechanism.
3. The battery is housed in a secure compartment directly beneath the seat.
4. Disconnect the negative terminal (-) first, then the positive terminal (+) when removing.
5. When reinstalling, connect the positive terminal (+) first, followed by the negative terminal (-).

Important:

- Only use a compatible battery with identical specifications: 12V – 11.5Ah or equivalent.
- Avoid short circuits or reverse polarity when handling battery terminals.
- If the motorcycle is not used for extended periods, disconnect the battery or use a smart charger to maintain optimal charge levels.

Tip: Periodically check the battery terminals for corrosion. Clean and apply dielectric grease if needed to ensure solid connections.



PHELON & MOORE

MOTORS

Brake fluids

Your motorcycle is equipped with two brake-fluid reservoirs, each serving a vital role in the braking system:

- The front reservoir is positioned above the right handlebar grip and supplies the front brake.
- The rear reservoir is located beneath the passenger seat, supplying the rear brake.

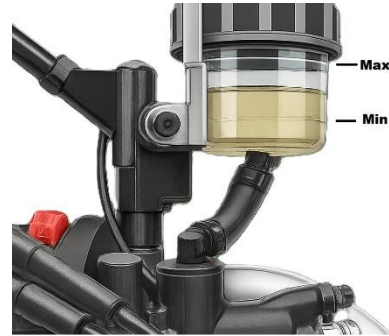

Only use DOT 4 brake fluid.

Using the incorrect type of fluid can severely compromise braking performance and safety.

Inspection

Check the fluid level regularly through the translucent windows on each reservoir:

1. Keep the motorcycle upright and on level ground.
2. Observe the fluid level through the viewing window.
3. The level must be between the MIN and MAX marks on the reservoir.

PHELON & MOORE

MOTORS



Caution:
Brake fluid is hygroscopic, meaning it absorbs moisture from the air. Contaminated or old fluid can reduce braking efficiency. Avoid contact with painted surfaces as brake fluid may cause damage.

Topping Up

If the brake fluid is below the minimum mark:

- Carefully clean around the reservoir cap to prevent contamination.
- Remove the cap and top up only with DOT 4 fluid from a sealed container.
- Do not overfill. Replace the cap securely.

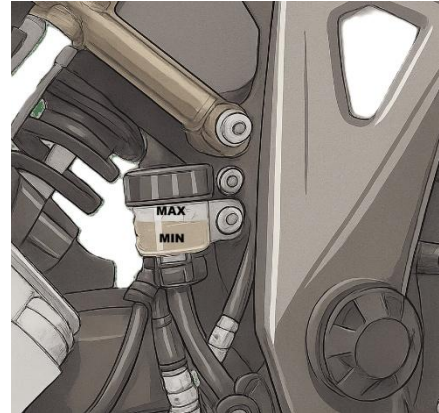



Braking system, wheels, and tires

Phelon & Moore's lightweight yet robust alloy wheels are engineered for a balance of strength and agility. Visually inspect your wheels periodically for dents, cracks, or corrosion—particularly after impacts or off-road use. Damaged rims can impair handling and safety.

If any deformation or damage is noted, visit your nearest Phelon & Moore Authorized Service Centre for evaluation.

PHELON & MOORE

MOTORS

Tire Wear Monitoring

Tires have wear indicators, small raised sections integrated into the tread pattern. When the surrounding tread has worn down to the level of these indicators, it is time to replace the tire. Continuing to ride on worn tires compromises safety, grip, and comfort.

Regular Inspection

We recommend inspecting your tires regularly for:

- Uneven wear
- Cracks or cuts
- Embedded objects (nails, stones, etc.)
- Sidewall damage
- Excessive flattening (especially at the center tread)

Always check tires when the motorcycle is upright and on a level surface, with cold tires for accurate pressure readings.



PHELON & MOORE

MOTORS

Braking System

The Panhette X is equipped with a two hydraulic independent service brakes with ABS acting on each axle by right hand lever (front) and left hand lever (rear)

Specifications

- Front: 1 x Ø 240mm discs hydraulically actuated with master cylinder Ø 12.7mm, floating caliper with 2 parallel pistons of Ø 25mm.
- Rear: 1 x Ø 220mm disc hydraulically actuated with master cylinder Ø 12.7mm and caliper with 1 wheel cylinder of Ø 34mm.

User Guidance

- Apply the front brake lever progressively to maintain stability and maximize ABS performance.
- Avoid continuous hard braking on long descents to prevent overheating.



PHELON & MOORE

MOTORS

- If you notice reduced braking performance, unusual noises, or vibration, have the system inspected by an authorized Phelon & Moore service center.



Warning: Never modify the braking system or replace components with non-approved parts. Doing so may compromise safety and void the warranty.

This setup provides consistent, progressive braking with excellent feel at the lever. ABS and TCS enhance control, especially in emergency stops and low-grip conditions.

PHELON & MOORE

MOTORS

Brake Pad Wear

Brake pads must be inspected regularly for wear. Look through the caliper window or inspection slots—if the pad material is approaching the minimum thickness mark, replacement is required.

Maintenance schedules

Proper maintenance is essential to ensure the safety, performance, and long-term reliability of your Phelon & Moore motorcycle. Regular care not only helps to preserve the value of your vehicle but also guarantees an optimal riding experience across varying road and weather conditions.

This section of the manual outlines the key inspection points, service intervals, and recommended procedures to keep your motorcycle in top condition.

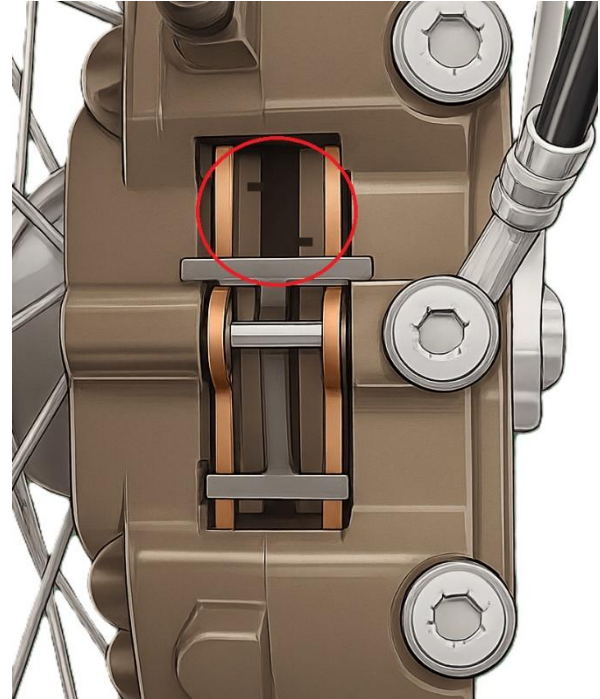

PHELON & MOORE

MOTORS



Attention:

Routine maintenance should be performed as outlined in the Scheduled Maintenance Chart included in this manual. For any service involving complex mechanical components or electronic systems, we strongly recommend contacting an authorized Phelon & Moore Service Center.

Engine								
Regular Replacement Items	Odometer reading (in KM)							
	Every	1000	5000	10000	15000	20000	25000	30000
Clean air filter element - Cleaning				x		x		x
Valve clearance - Inspection	20,000 KM							
Check throttle system (clearance, flexible return) - Inspection	1 year	x		x		x		
Idle speed - Inspection		x		x		x		x
Fuel leak (fuel pipe) - Inspection	1 year	x		x		x		x
Fuel pipe damage - Inspection	1 year			x		x		x
Fuel pipe installation - Inspection	1 year	x		x		x		x
Throttle valve body -Cleaning				x		x		x
Coolant volume - Inspection		x		x		x		x
Coolant leak - Inspection	1 year	x		x		x		x
Damage to radiator and pipeline -Inspection	1 year	x		x		x		x
Radiator and pipeline installation - Inspection	1 year	x		x		x		x
Intake system damage - Inspection				x		x		x

PHELON & MOORE

MOTORS

Damping							
Item and Action	Every	Odometer reading (in KM)					
		1000	5000	10000	15000	20000	25000
Front fork/rear suspension (regular suspension inspection)				x		x	x
Front fork/rear suspension hydraulic oil leakage - Inspection	1 year			x		x	x

Clutch and drive chain							
Item and Action	Every	Odometer reading (in KM)					
		1000	5000	10000	15000	20000	25000
Clutch operation (clearance, engagement, disengagement) - Inspection		x		x		x	x
Transmission chain Lubrication - Inspection*	600 KM						
Transmission chain tightness - Inspection*	1,000 KM						
Wear of transmission chain - Inspection*				x		x	x
Wear condition of transmission chain guard - Inspection				x		x	x

Rim and tire, crown wheel flexible coupling bearing							
Item and Action	Every	Odometer reading (in KM)					
		1000	5000	10000	15000	20000	25000
Tire pressure - Inspection		x		x		x	x
Rim/tyre damage - Inspection				x		x	x
Tire surface wear and abnormal wear - Inspection				x		x	x
Crown wheel flexible coupling - Inspection	1 year			x		x	x
Pedal - Lubrication		x		x		x	x
Sprocket seat bearing - Inspection				x		x	x

PHELON & MOORE

MOTORS

Braking system								
Item and Action	Every	Odometer reading (in KM)						
		1000	5000	10000	15000	20000	25000	30000
Brake fluid leakage - Inspection	1 year	x	x	x	x	x	x	
Damage to the brake fluid pipe - Inspection	1 year	x	x	x	x	x	x	
Brake pad wear - Inspection*			x	x	x	x	x	
Brake fluid pipeline installation - Inspection	1 year	x	x	x	x	x	x	x
Brake fluid volume - Inspection	6 months	x	x	x	x	x	x	x
Brake control (braking force, clearance flexible action) - Inspection	1 year	x	x	x	x	x	x	x
Brake light switch operation - Inspection		x	x	x	x	x	x	x

Control system								
Item and Action	Every	Odometer reading (in KM)						
		1000	5000	10000	15000	20000	25000	30000
Steering clearance - Inspection	1 year	x		x		x		x
Steering bearing - Lubrication	2 years					x		

Electrical system								
Item and Action	Every	Odometer reading (in KM)						
		1000	5000	10000	15000	20000	25000	30000
Light and switch operation - Inspection	1 year			x		x		x
Headlight - Inspection	1 year			x		x		x
Temple flameout switch operation - Inspection	1 year			x		x		x
Engine flameout switch operation - Inspection	1 year			x		x		x

PHELON & MOORE

MOTORS

Chassis							
Item and Action	Every	Odometer reading (in KM)					
		1000	5000	10000	15000	20000	25000
Chassis parts - Lubrication				x		x	x
Bolt and nut torque - Inspection		x		x		x	x

Final Message to the Rider

Thank you for choosing Phelon & Moore. This motorcycle is the result of decades of engineering heritage, innovation, and a passion for riding.

This Owner's Manual has been designed to help you get the most from your motorcycle—both in terms of performance and safety. Whether you're embarking on a long-distance tour or enjoying your daily ride, we encourage you to ride responsibly, perform regular maintenance, and always respect local traffic laws.

Your motorcycle is more than a machine—it's your partner on the road. Treat it with care, and it will reward you with reliability, performance, and unforgettable adventures.

Ride safe. Ride smart. Ride free.

The Phelon & Moore Team

